

executive

o2



**ISIXTY**  
collection

# INDEX

## Avantgarde

# 01



Corda | Dove grey | Chromed

p. 10

# 02



Silicio | Cream | Golden

p. 14

# 03



Tabacco | Dove grey | Chromed

p. 18

# 04

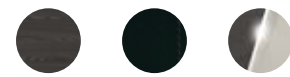

Silicio | Black | Chromed

p. 22

# 05



Corda | Cream | Golden

p. 26

## Luxury

# 06



Corda | Silver | Chromed

p. 32

# 07



Tabacco | Coffee | Golden

p. 36

# 08



Silicio | Golden

p. 40

# Avantgarde

avanguardia e intraprendenza

L'ufficio del futuro è già qui, lo vedi, e incarna perfettamente ciò che ancora non riuscivi ad immaginare.

Quello che non vedi è il suo cuore hi-tech, perché la tecnologia è tanto più presente quanto meno visibile. Avantgarde è il lato intraprendente di iSixty. È lo stile di vita di chi sa anticipare il tempo con il giusto equilibrio di consapevolezza e genialità.

Le essenze di legno frassino tinto corda, tabacco o silicio segnano le linee curve con venature decise e una finitura matt piacevole al tatto. Si sposano a rivestimenti in cuoio dal carattere sofisticato nelle nuance nero, tortora e crema.

The office of the future is already here, you can see it, and it perfectly embodies what, until now, you were unable to imagine. What you can't see is its hi-tech heart, because technology is all the more present when it is less evident.

Avantgarde is the enterprising side of iSixty. It is the lifestyle of the future with just the right balance of awareness and cleverness.

The corda, tabacco or silicio dyed ash wood highlights the curved lines with prominent grains and a matt finish that is pleasant to the touch. A perfect match for the thick leather upholstery with its sophisticated character in shades of black, dove grey and cream.



**01** AVANTGARDE  
CORDA | DOVE GREY | CHROMED



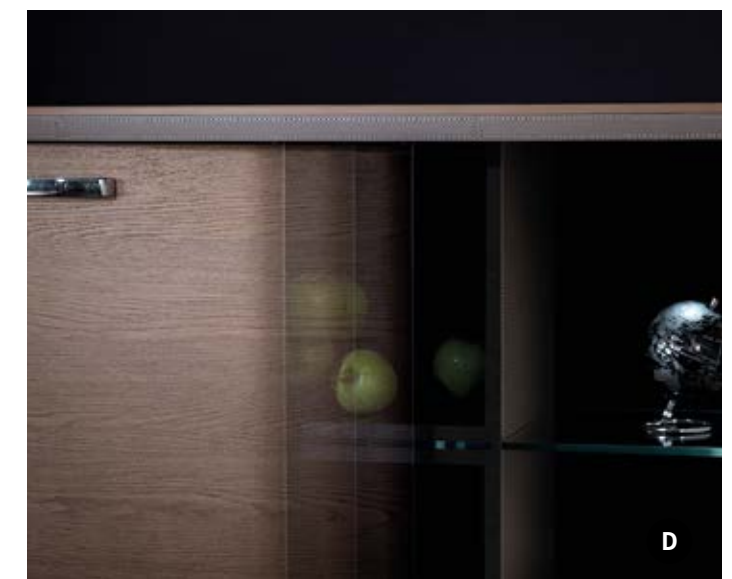

Dati Tecnici | Technical Data

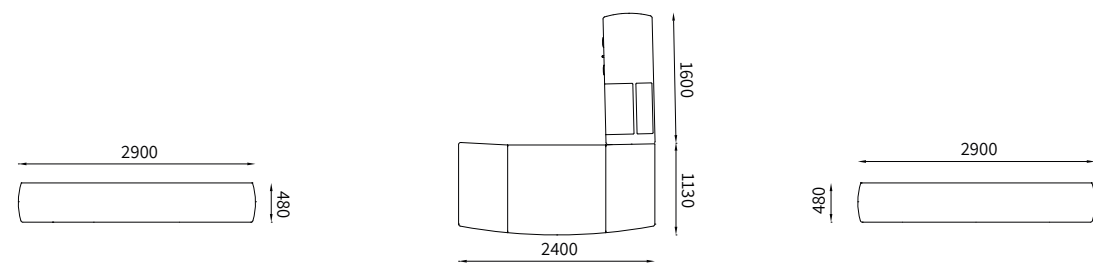

Finiture | Finishes

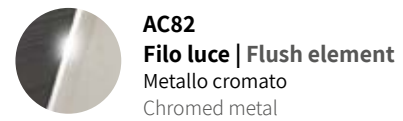
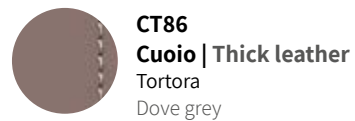

**A** Cassetto Secretaire con chiusura elettronica o a chiave: gli oggetti più preziosi sono al sicuro all'interno del fianco della scrivania.  
"Secretaire" drawer with electronic or key lock: precious objects are safe inside the side of the desk.

**B** Cassettino scorrevole push-open integrato nello spessore del piano: vi si può riporre comodamente tastiera e mouse.  
Sliding push-open drawer integrated in the thickness of the table: designed to contain keyboard and mouse.

**C** Portamonitor a scomparsa con telecomando. Lo sportello di chiusura complanare è rivestito in cuoio cucito a punto sella.  
Foldaway monitor table with remote control. The coplanar overlapping door is upholstered with saddle-stitched thick leather.

**D** Anta bombata con apertura scorrevole rifinita con fili luce cromati o dorati 24 carati.  
Convex door with sliding opening finished with chrome-plated or 24-carat gold-plated flush bands.

02 AVANTGARDE  
SILICIO | CREAM | GOLDEN



**Finiture | Finishes**



**GL20**  
**Legno | Wood**  
Frassino tinto Silicio  
Silicio dyed ash



**CC82**  
**Cuoio | Thick leather**  
Crema  
Cream

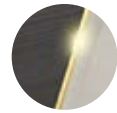

**AD80**  
**Filo luce | Flush element**  
Metallo dorato 24k  
Golden metal 24k

**Dati Tecnici | Technical Data**

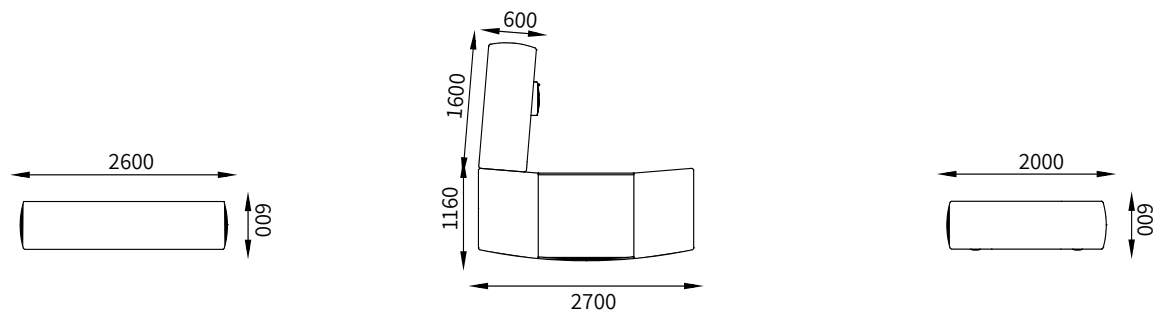

Piano inferiore rivestito in cuoio, divisori in vetro ultrachiaro, mensola in essenza di legno frassino.

Lower top upholstered in thick leather, ultralight glass partitions, ash wood shelves.



**A** Sistema di illuminazione esterna tramite faretti a led collocati sotto il top superiore.

External lighting system by means of spotlights and LEDs located underneath the upper top.

**B** Modulo centrale con anta scorrevole. Disponibile anche con ante a battente dotate di chiusura soft.

Central module with sliding door. Also available with single-action doorfeaturing soft closing.



**03** AVANTGARDE  
TABACCO | DOVE GREY | CHROMED





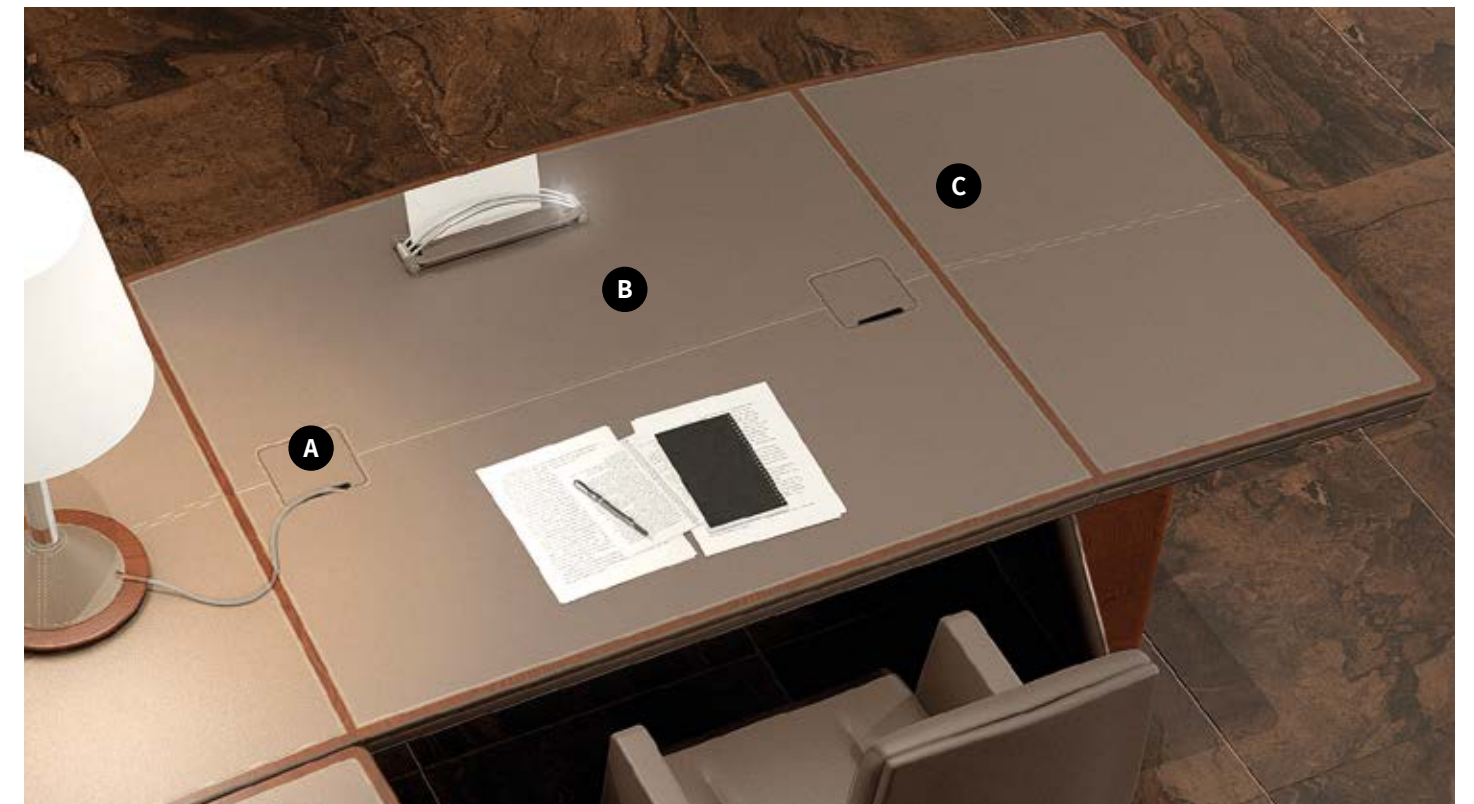

- A** Passacavi di serie per l'accesso alla canalizzazione predisposta all'interno dei fianchi.  
Standard fairleads for accessing the ducts inside the side panels.
- B** Piano centrale della scrivania: è sempre rivestito in cuoio installato intarsiato sul legno.  
Central desktop: again upholstered in thick leather inlaid on the wood.
- C** Piani laterali della scrivania: possono essere in legno oppure rivestiti in cuoio installato a intarsiato sul legno.  
Desk side tops: these can be in wood or upholstered in thick leather inlaid on the wood.

**Finiture | Finishes**

**GA21**  
**Legno | Wood**  
Frassino tinto Tabacco  
Tabacco dyed ash

**CT86**  
**Cuoio | Thick leather**  
Tortora  
Dove grey

**AC82**  
**Filo luce | Flush element**  
Metallo cromato  
Chromed metal

**Dati Tecnici | Technical Data**

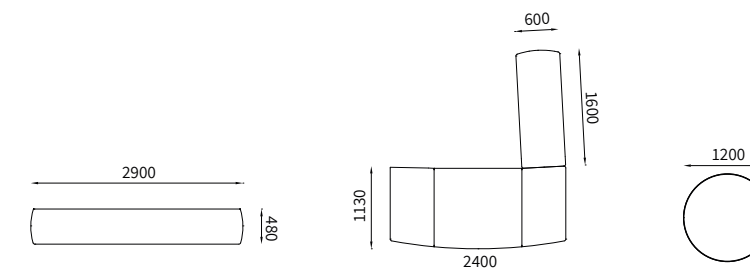

**04** AVANTGARDE  
SILICIO | BLACK | CHROMED



- A** Fascia tecnica centrale in cuoio complanare al legno.  
Central technical strip in leather coplanar with wood.
- B** All'interno degli sportellini possono essere collocate apposite multiprese.  
Special multi-sockets can be positioned inside the doors.



**Dati Tecnici | Technical Data**

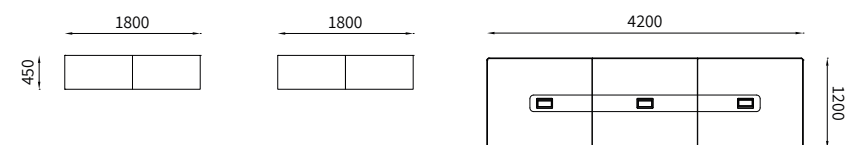

**Finiture | Finishes**

- GL20**  
**Legno | Wood**  
Frassino tinto Silicio  
Silicio dyed ash
- CN72**  
**Cuoio | Thick leather**  
Nero  
Black
- AC82**  
**Filo luce | Flush element**  
Metallo cromato  
Chromed metal

**05** AVANTGARDE  
CORDA | CREAM | GOLDEN





**A** Incavo del bracciolo e fregio sullo schienale: possono essere in tinta con il rivestimento oppure in pelle oro o argento.  
 Arm hollow and frieze pattern on back: they are available in the same colour as the upholstery or in thin leather with gold or silver finish.



**B** La base a razza e la base a slitta sono disponibili in legno frassino oppure in alluminio.  
 The spoked base and the slide base are available in ash wood or aluminium.

#### Finiture | Finishes



**GC22**  
**Legno | Wood**  
 Frassino tinto Corda  
 Corda dyed ash



**CC82**  
**Cuoio | Thick leather**  
 Crema  
 Cream

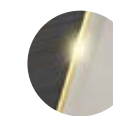

**AD80**  
**Filo luce | Flush element**  
 Metallo dorato 24k  
 Golden metal 24k

#### Dati Tecnici | Technical Data

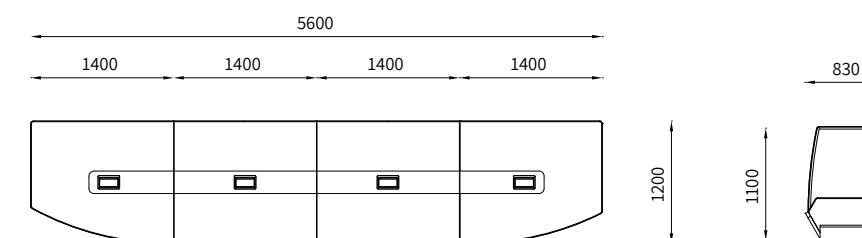

# Luxury

l'eleganza e il prestigio

Una scelta estetica che proietta nel futuro quei canoni di eleganza che in passato hanno connotato gli alti livelli del business design. Arredi, sedute, divani, accessori, tecnologia: il risultato è un tesoro di gioielli prestigiosi. Luxury è il lato regale di iSixty, è lo stile di vita di chi sa distinguersi attraverso l'eleganza.

È la brillantezza delle preziose superfici rivestite in pelle oro e argento a catturare gli sguardi. Le essenze di legno frassino tinto corda, tabacco o silicio, sembrano essere incastonate tra i raffinati fili luce cromati o dorati 24 K.

An aesthetic choice that projects into the future those standards of elegance which in the past distinguished high levels of business design. Furnishings, seating systems, sofas, accessories, technology: the result is a treasure of prestigious gems. Luxury is the regal side of iSixty, it is the lifestyle of those who stand out from the crowd through elegance.

It is the brightness of precious surfaces covered in gold and silver leather to capture gazes. The corda, tabacco or silicio dyed ash wood, seems set amid the refined chromeplated or 24-carat gold-plated flush bands.



**06** LUXURY  
CORDA | SILVER | CHROMED



**A** La forma del nuovo tavolo riunione semiovale porta l'attenzione sul leader.  
The shape of the new semioval table places focus on the meeting leader.

**B** Le giunzioni tra i top dei tavoli sono impreziosite da un filo luce in acciaio cromato o dorato 24 K.  
The joints between table tops are enhanced by a steel chrome-plated or 24-carat gold-plated flush band.

**Dati Tecnici | Technical Data**

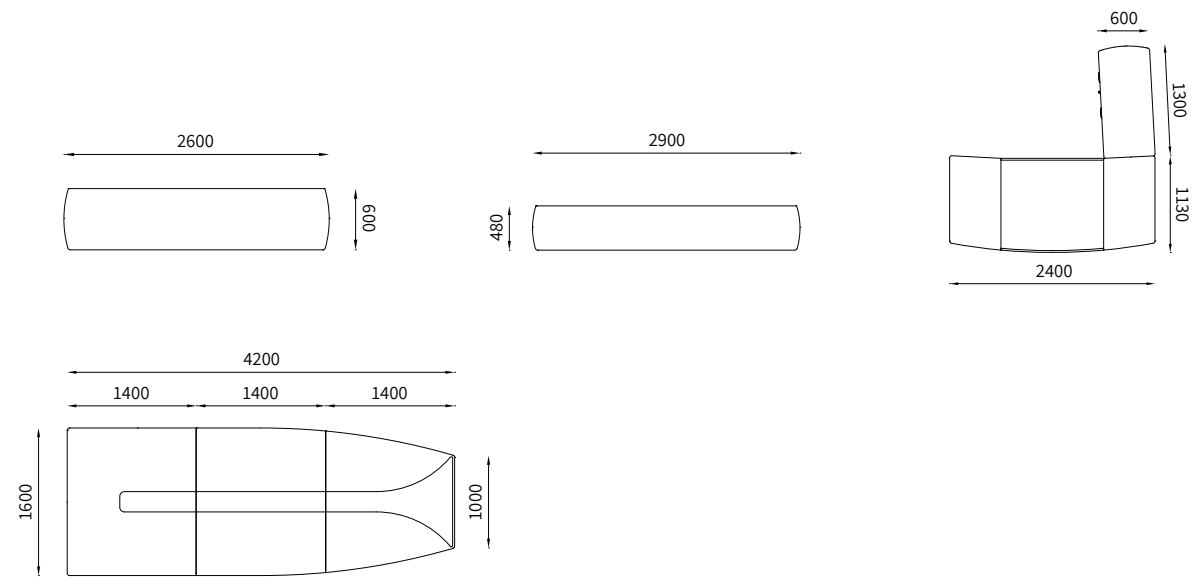

**Finiture | Finishes**

**GC22**  
**Legno | Wood**  
Frassino tinto Corda  
Corda dyed ash

**CS88**  
**Cuoio | Thick leather**  
Argento  
Silver

**AC82**  
**Filo luce | Flush element**  
Metallo cromato  
Chromed metal

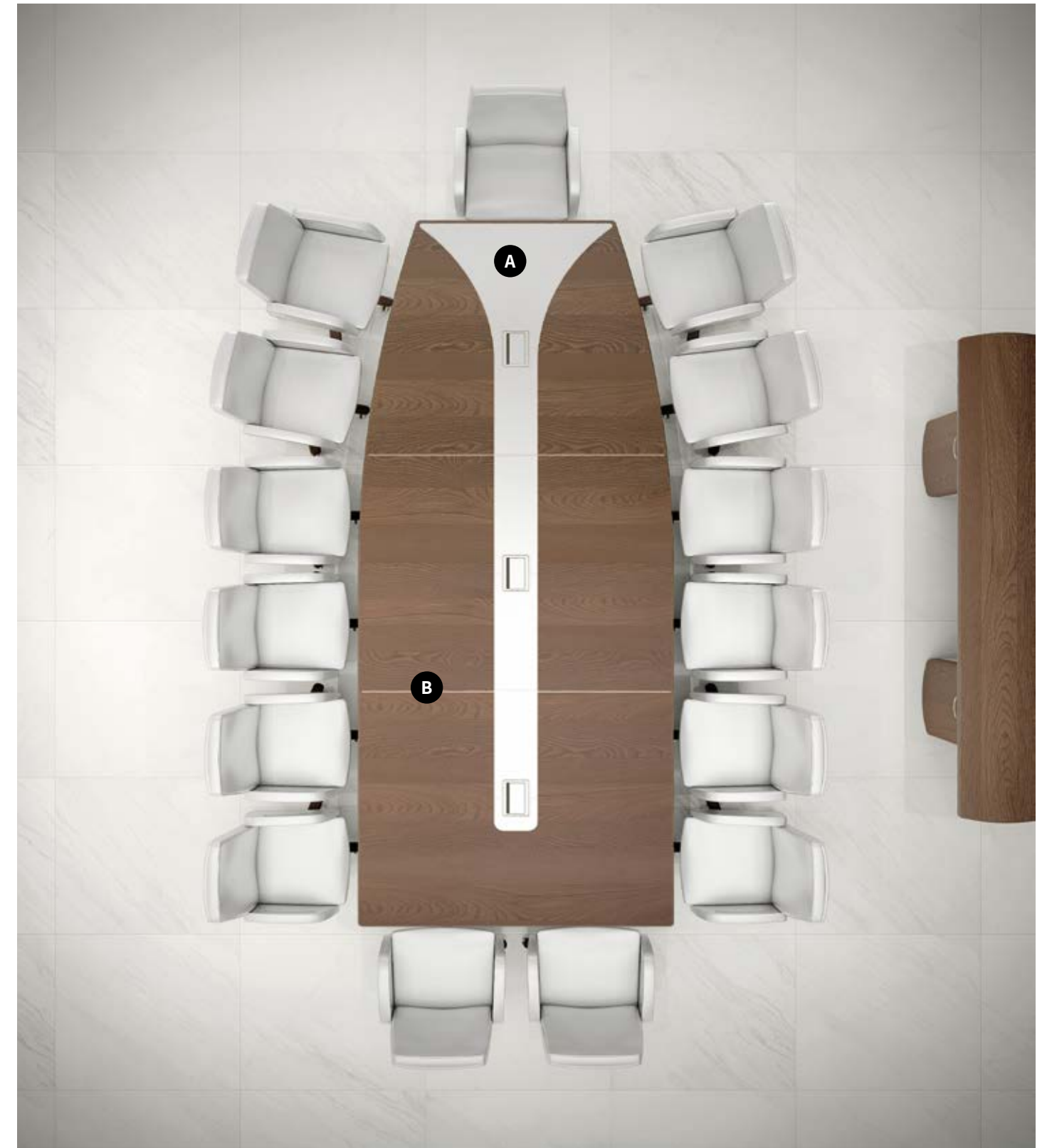



**07** LUXURY  
TABACCO | COFFEE | GOLDEN



**A** Carica batterie ad induzione integrato nel piano, per smartphone e tablet compatibili.

Induction battery charger integrated in top, for compatible smartphones and tablets.

**B** Sistema di illuminazione esterna tramite faretti a led collocati sotto il top superiore.

External lighting system by means of spotlights and LEDs located underneath the upper top.



Maniglie cromate o placcate in oro 24 carati, disponibili anche con rivestimento in pelle o cuoio.

Chrome-plated or 24-carat gold plated handles, also available with leather covering.

#### Dati Tecnici | Technical Data

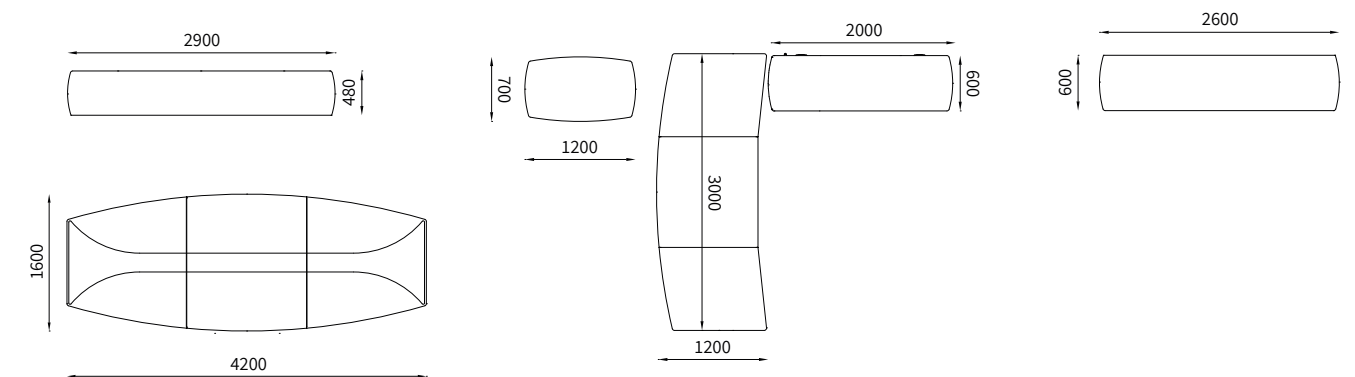

#### Finiture | Finishes

- 

**GA21**  
Legno | Wood  
Frassino tinto Tabacco  
Tabacco dyed ash
- 

**CL84**  
Cuoio | Thick leather  
Caffè  
Coffee
- 

**CD87**  
Cuoio | Thick leather  
Oro  
Gold
- 

**AD80**  
Filo luce | Flush element  
Metallo dorato 24k  
Golden metal 24k

08 LUXURY  
SILICIO | GOLDEN





Dati Tecnici | Technical Data

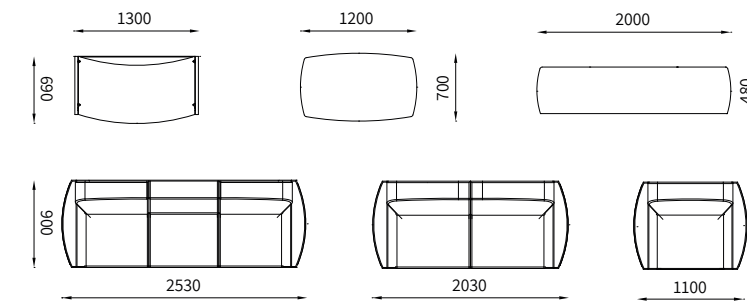

**A** Il frontale curvo rivestito in pelle è rifinito da una cucitura centrale in punto sella eseguita a mano.  
The leather-covered curved front is finished off with hand saddle stitching.

**B** Frigo a condensazione opzionale: occupa uno dei due vani del mobiletto.  
Optional condensation refrigerator: occupies one of the two compartments of the unit.

Finiture | Finishes

**GL20**  
**Legno | Wood**  
Frassino tinto Silicio  
Silicio dyed ash

**CD87**  
**Cuoio | Thick leather**  
Oro  
Gold

**AD80**  
**Filo luce | Flush element**  
Metallo dorato 24k  
Golden metal 24k

codutti

# CODUTTI SOUND OFFICE

## the hi-fi writing desk

Musica e design si incontrano in  
un'armonia unica.  
Dal cuore vibrante della scrivania una  
magica atmosfera invade l'ambiente.

Music and design meet in a unique  
harmony.  
From the vibrant heart of the desk  
a magical atmosphere invades the  
environment.



**CHOOSE YOUR MUSIC**

# Scrivania o cabina di regia?

## Writing desk or control room?

Lavorare telefonando senza il dispositivo in mano o rilassarsi ascoltando musica in Hi-Fi? Tutto questo è Soundoffice.

Working on the phone without having to hold it in your hand or relaxing while listening to Hi-Fi music? All this is Soundoffice.



# Scrivania o cassa armonica?

## Writing desk or soundbox?

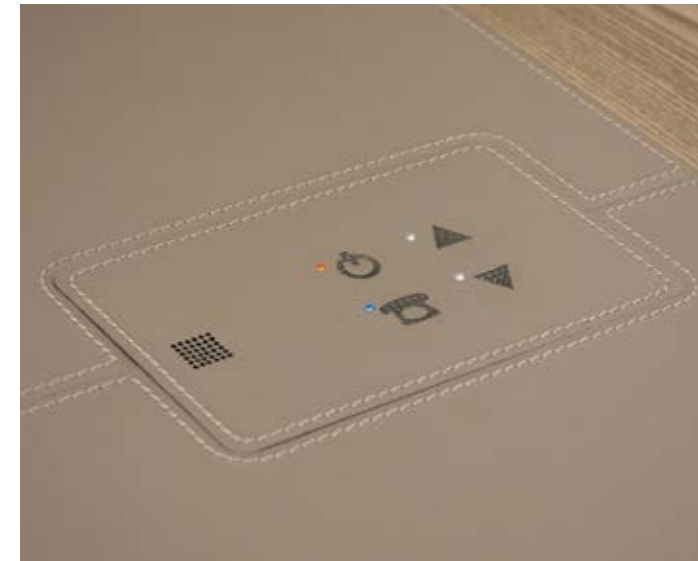

### A Controlli | Controls

Una gestione facile ed intuitiva dei comandi consente la regolazione del volume, la risposta alle chiamate in arrivo e l'interazione di Soundoffice con i dispositivi multimediali. Questi ultimi si possono connettere alla scrivania attraverso il cavo Audio Mini-Jack o attraverso il protocollo di comunicazione senza fili Bluetooth.

Easy-to-adjust and intuitive controls for regulating volumes, incoming call answering and Soundoffice interaction with multi-media devices. The latter can be connected to the writing desk by means of the Audio Mini- Jack lead or through the communication protocol without Bluetooth wires.

Microfono | Microphone

On / Off

Chiamata | Call

Volume - / Volume +

Ø 3.5 mm audio mini-jack

Bluetooth

### B Casse acustiche | Loudspeakers

Il suono ricco e dettagliato sembra provenire dalle pareti, dal soffitto, dal pavimento, pervade l'ambiente e rapisce con sonorità coinvolgenti. I diffusori, che alloggiato all'interno dei fianchi, si trovano nella posizione ottimale per l'ascolto da parte di chi siede alla scrivania.

- Casse acustiche con potenza nominale di 20W a 8 ohm e risposta di 95-22.000 Hz
- Amplificatore stereo hi-fi con frequenze tra i 20 e 20.000Hz

The rich and detailed sound seems to come from the walls, the ceiling, the floor and pervades the environment and enraptures with fascinating sound effects. The speakers, housed inside the side panels, are perfectly positioned for listening by anyone sat at the desk.

- Loudspeakers with 20W nominal power at 8 ohm and 95 - 22.000 Hz response.
- Stereo hi-fi amplifier with frequency between 20 and 20.000Hz.

### C Canalizzazione | Ducting

I cavi che alimentano Soundoffice transitano dal vano di diffusione alla canalizzazione collocata all'interno dei fianchi, per poi raggiungere il pavimento tramite l'apertura posta ai piedi del fianco stesso.

The Soundoffice power leads transit from the speaker compartment to the ducts located inside the side panels before reaching the floor through the hole at the foot of the side panels themselves.

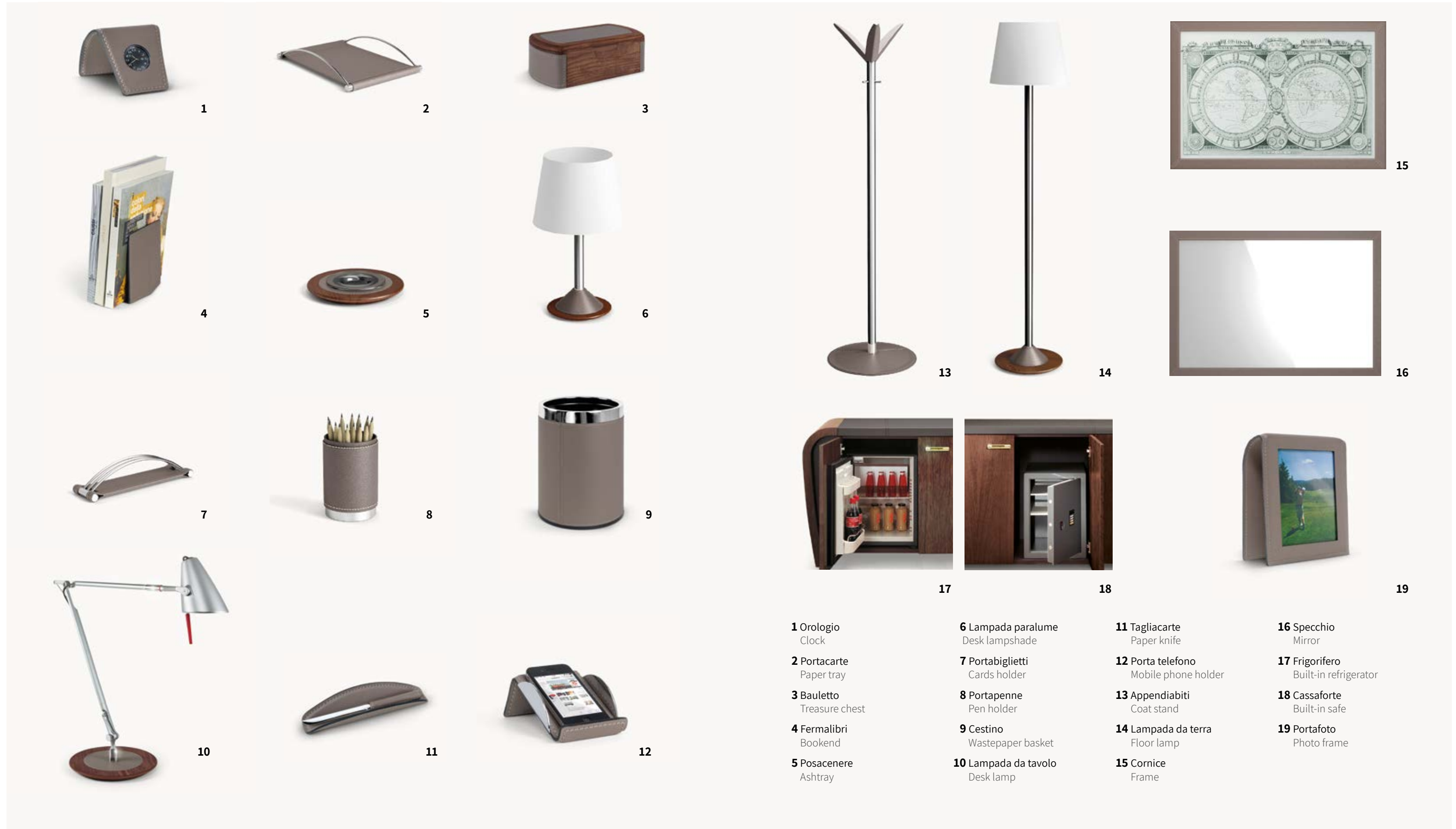

- |                                     |   |   |  |
|-------------------------------------|---|---|--|
| <b>1</b> Orologio<br>Clock          | <b>6</b> Lampada paralume<br>Desk lampshade | <b>11</b> Tagliacarte<br>Paper knife            | <b>16</b> Specchio<br>Mirror                   |
| <b>2</b> Portacarte<br>Paper tray   | <b>7</b> Portabiglietti<br>Cards holder     | <b>12</b> Porta telefono<br>Mobile phone holder | <b>17</b> Frigorifero<br>Built-in refrigerator |
| <b>3</b> Bauletto<br>Treasure chest | <b>8</b> Portapenne<br>Pen holder           | <b>13</b> Appendiabiti<br>Coat stand            | <b>18</b> Cassaforte<br>Built-in safe          |
| <b>4</b> Fermalibri<br>Bookend      | <b>9</b> Cestino<br>Wastepaper basket       | <b>14</b> Lampada da terra<br>Floor lamp        | <b>19</b> Portafoto<br>Photo frame             |
| <b>5</b> Posacenere<br>Ashtray      | <b>10</b> Lampada da tavolo<br>Desk lamp    | <b>15</b> Cornice<br>Frame                      |  |



# Rainbow

I colori ed i loro abbinamenti esprimono chi sei. Poterli scegliere significa trovare la libertà di esprimersi e l'occasione di trasmettere un messaggio a chi ti circonda. Rainbow è il progetto che permette di personalizzare il colore di ogni collezione scegliendo tra le numerose finiture di cuoio previste nel Campionario Finiture Codutti.

The colours and the way they are matched tell who you are. Being able to choose them means having the freedom to express yourself and the chance to send a message to those around you. Rainbow is the project which permits personalizing the colour of every collection, choosing from among the numerous leather finishes in the Codutti Sample Book.



AVANTGARDE

Legno | Wood

**GC22**  
Frassino tinto Corda | Corda dyed ash



**GA21**  
Frassino tinto Tabacco | Tabacco dyed ash



**GL20**  
Frassino tinto Silicio | Silicio dyed ash

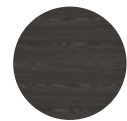

**CC82**  
Crema | Cream



**CT86**  
Tortora | Dove grey



**CN72**  
Nero | Black

Cuoio | Leather

**AC82**  
Metallo cromato | Chromed metal

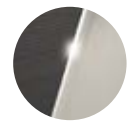

**AD80**  
Metallo dorato 24k | Golden metal 24k

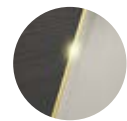

Filo luce | Flush element

Legno | Wood

**GC22**  
Frassino tinto Corda | Corda dyed ash



**GA21**  
Frassino tinto Tabacco | Tabacco dyed ash



**GL20**  
Frassino tinto Silicio | Silicio dyed ash

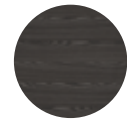

LUXURY

Cuoio | Leather



**CS88**  
Argento | Silver



**CD87**  
Oro | Gold

**AC82**  
Metallo cromato | Chromed metal

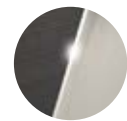

**AD80**  
Metallo dorato 24k | Golden metal 24k

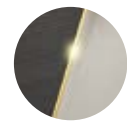

Filo luce | Flush element

**Il legno presente nelle collezioni direzionali Codutti è un materiale naturale. Per questo motivo differenze nelle caratteristiche cromatiche e di venatura presenti in ogni singolo elemento d'arredo, sono considerati segni distintivi di pregio.**

Il cuoio e la pelle sono materiali diversamente trattati, quindi diversa è la rifrazione della luce che determina il tono del colore. Le cuciture di pelle e cuoio possono presentare irregolarità nel tratto e variazioni di linea. Pertanto differenze di tono del colore e lievi imperfezioni nelle cuciture devono essere accettate quale segno dell'unicità e della cura artigianale del prodotto. Codutti Furniture S.r.l. si riserva di apportare qualsiasi modifica alle Collezioni presenti in questo catalogo ogni volta che lo ritenga opportuno.

**The wood in Codutti's executive collections is natural material. Any differences in terms of color and veining between individual pieces of furniture are therefore considered as characteristic and distinctive markings.** Thick leather and thin leather undergo different curing processes. As a result, the surfaces refract light differently and this determines a variation in the shade of the color. Moreover, the stitching in both thick and thin leather may appear irregular. Any differences in the shade of color and slight imperfections in the stitching are the natural consequence of the craftsmanship involved in the manufacturing process, which makes each product unique. Codutti Furniture S.r.l. is entitled to bring any modifications on Collections included in this catalogue at any time, without previous notice.

SCRIVANIE | WRITING DESK

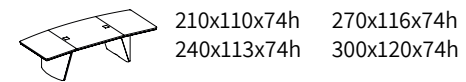

SCRIVANIE CON SCHIENALE | WRITING DESK WITH MODESTY

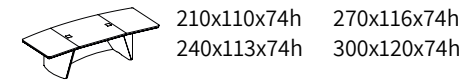

TAVOLI RIUNIONE OVALI | OVAL MEETING TABLES

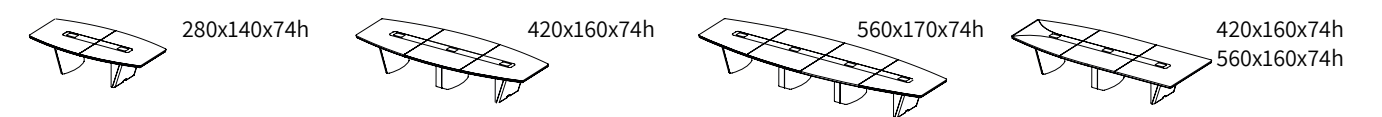

ALLUNGHI STANDARD | STANDARD EXTENSIONS

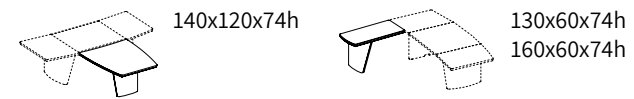

ALLUNGHI ATTREZZATI | EQUIPPED EXTENSIONS

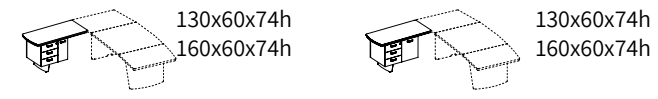

TAVOLI CONFERENZE | CONFERENCE TABLES

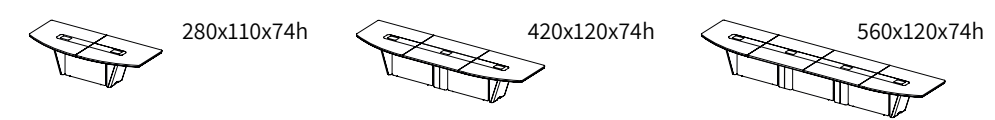

ALLUNGHI PC ATTREZZATI | PC EQUIPPED EXTENSIONS

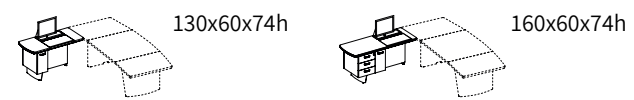

ALLUNGHI SU RUOTE | EXTENSIONS ON CASTORS

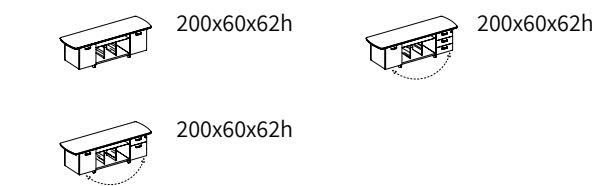

TAVOLI RIUNIONE | MEETING TABLES

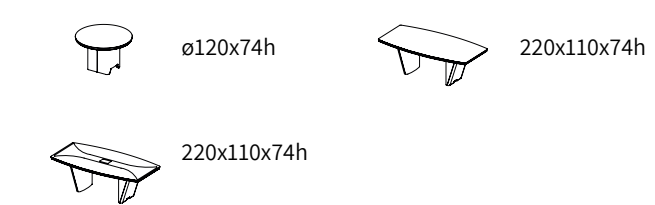

TAVOLI RIUNIONE MODULARI | MODULAR MEETING TABLES

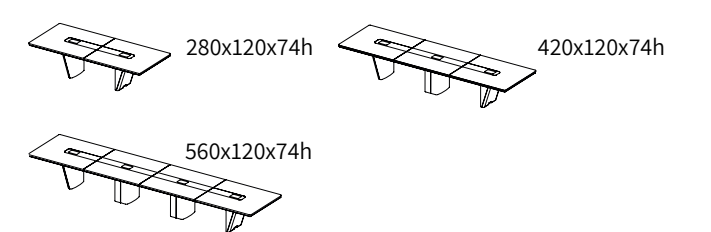

LIBRERIE CONSOLLE | CONSOLE BOOKCASES

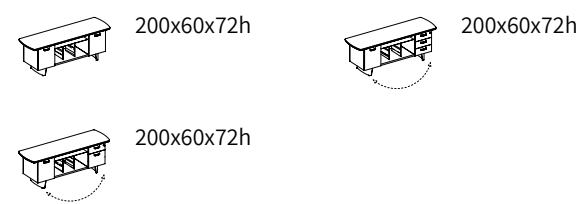

LIBRERIE CREDENZA | CREDENZA BOOKCASES

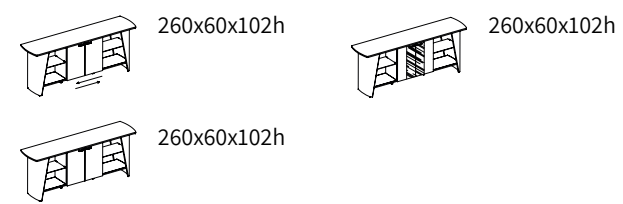

ARMADI | CABINETS

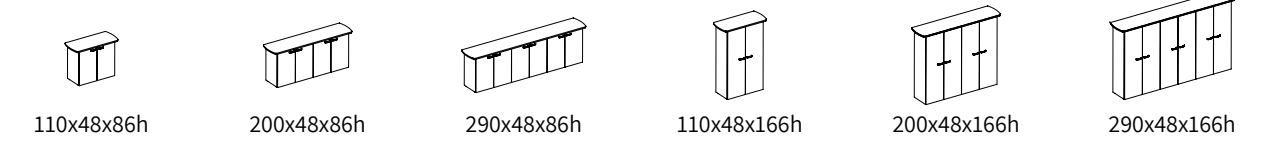

LIBRERIE COLONNA | COLUMN BOOKCASES

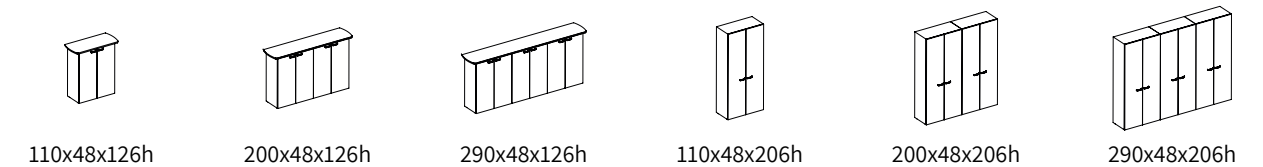
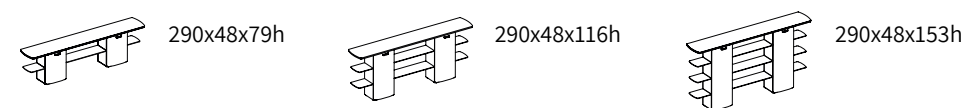

CASSETTIERE | DRAWER UNITS



TAVOLINI ATTESA | SIDE TABLES



MOBILE BAR | BAR CABINET

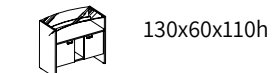

PULPITO | PULPIT

